

**K
B** **ELEMENTS**

**BUILT-IN ELECTRIC OVEN
ELK75EV1 - ELK75EV2**

USER MANUAL

Please read this manual carefully and retain for future references.

IMPORTANT SAFETY INSTRUCTIONS

- Ensure the oven is properly installed in accordance with national and local safety regulations and all electrical components are correctly set up before use.
 - Remove all packing parts, packing materials and all the protective film (except rating label) before use.
 - To prevent electric shock or fire hazards, do not damage, modify, expose to high temperatures, twist, hang, or pull the power cord too hard.
 - If the power cord is damaged, please contact nearest KB ELEMENTS point of sales for replacement.
 - Before first use, operate the oven empty to eliminate any manufacturing odors.
 - For safety, do not use sealed containers as they may burst under pressure.
 - Ensure the oven door remains closed during operation and is free from obstruction.
 - To prevent electric shock or injury, do not insert any objects, especially metal ones like wires, into the openings.
 - Wear heat-resistant gloves when handling during operation.
 - Do not install decorative door panels, as they may distort from overheating.
 - Maintain a safe distance from the oven during and after use, especially with children around, to avoid burns. Use only heat-resistant pottery inside to reduce fire hazards.
 - To prevent fire, burns, or injury from potential explosions due to pressure buildup, do not place flammable objects like plastic, aluminum foil, or unopened canned products inside the oven.
 - To avoid fire, always monitor the oven when cooking foods with fat or oil.
 - Avoid using the oven to heat the room, as this may cause a fire and reduce its lifespan.
 - Do not disassemble, repair, or modify it yourself. Please contact the nearest KB ELEMENTS point of sale.
 - Do not clean the oven door glass with a rough scrubber or sharp scraper, as it can scratch the glass and potentially cause it to break.
 - Do not clean with a steam cleaner.
 - This oven should be operated only by individuals who are physically, mentally, and sensory capable, unless under supervision or instruction. Ensure children are supervised to ensure their safety and prevent misuse.
 - In case of abnormal operation or malfunction, stop using the oven immediately and unplug it from the power source.
 - Please disconnect the power before replacing the oven's light to prevent the risk of electric shock.
 - Do not touch the bottom when the power is on.
 - Do not touch the sides of the oven door while closing it.
 - Do not leave sugary food residues (such as jam) in the oven.
 - Do not cover the bottom of the oven with aluminum foil, tin foil, or place pans and baking trays directly on the bottom.
 - During oven use, refrain from adding water directly to the baking pan if the surface is still very hot, as this may cause steam, burns, or damage to the enamel surface.
 - It's important to use cleaners that are specifically labeled for use in electric ovens to ensure safety and optimal cleaning results.
- (Avoid actions that could lead to insulation aging and oven damage.)

TECHNICAL SPECIFICATIONS

Model	ELK75EV1 - ELK75EV2
Input	AC 220-240V
Power	3000W
Rated frequency	50/60HZ
Product size(width * depth * height)	59.5cm X 49.4cm X 59.5cm
Capacity	73L

OVEN STRUCTURE

The Open space oven has a capacity of 73 litres and offers users the option of cooking on 5 shelves at the same time or cooking large quantities which would not necessarily be possible in a traditional oven.

- The first time you use your oven , heat the empty oven with its door closed at its maximum temperature for at least half an hour . Make sure that the room is well ventilated before switching the oven off and opening the oven door . The oven may emit a slightly unpleasant odour caused by protective substances used during the manufacturing process burning away.
- Never put objects directly on the bottom of the oven ; this will prevent the enamel coating from being damaged.
- Always place cookware on the rack (s) provided.
- We suggest not opening the door when cooking foodstuffs which require leavening , so as to not compromise cooking results.

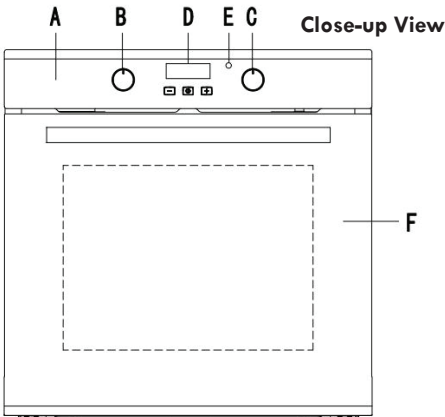

- A. Control Panel
- B. Knob for selecting the cooking features.
- C. Knob for adjusting the cooking temperature.
- D. Electronic cooking programmer
- E. Function of light – When the light is on, it indicates that the oven is heating. It will turn off when the temperature setting has been reached.
- F. Glass oven door

FASTENING THE OVEN

Insert the Oven into the compartment; open the oven door and fasten the oven to the cabinet using the two screws "A".

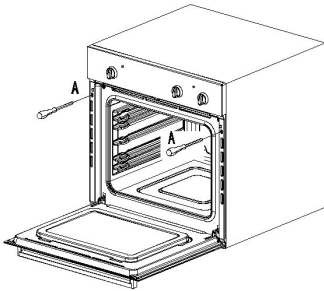

INSTALLATION

Important: the power supply to the oven must be cut off before any adjustments or maintenance work is done on it.

Installation of Built-in Ovens

To ensure the proper working order of the built-in appliance, the kitchen unit must be of a suitable size. The sizes of the unit for installing the cooker under a worktop or in a column unit are shown in figure.

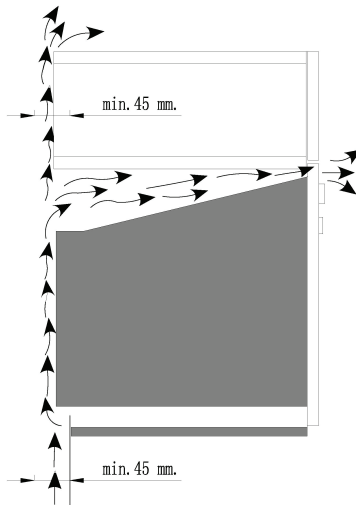

To provide adequate ventilation, there must be appropriate ventilation openings in the front bottom and the top part of 200 cm² , and an exhaust opening on the bottom of an least 200 cm² , and an exhaust opening of at least 60 cm² .

The unit panels next to the cooker must be heat resistant. In the case of veneered wood units, glues must be resistant to a temperature of 120°C.

In accordance with safety standards, once the appliance has been mounted, there must be no possible contact with electrical parts. Any protective parts must be secured so that they can only be removed with the use of tools.

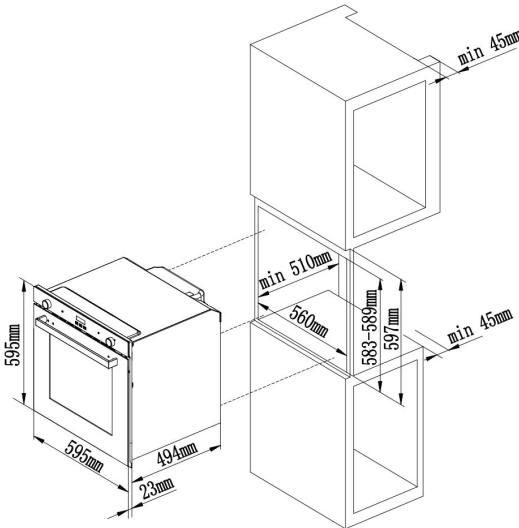
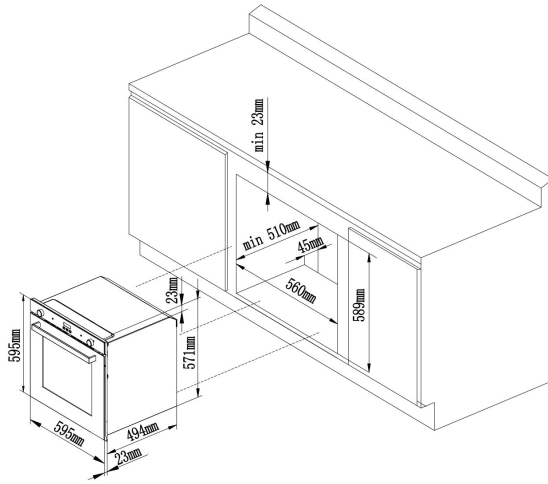

REPLACING THE LAMP IN THE OVEN

- Cut off the supply of power to the oven by turning off the omni-polar switch connecting it to the mains, or by removing the plug if it is accessible; Avoids appearing the electric shock;
- Unscrew the glass cover attached to the lamp holder;
- Pull out the lamp and replace it with another high-temperature lamp (300°C) with the following characteristics:

- Voltage: AC 230V
- Wattage: 25W
- Socket: G9

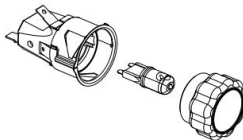

- Remount the glass cover and reconnect the appliance to the power supply.

WARNING: Ensure that the oven is switched off before replacing the lamp to avoid the possibility of electric shock.

FUNCTIONS

1. Oven light
2. Defrost
3. Top and bottom heat
4. Circle Fan Heater
5. Grill
6. Maxi grill
7. Convection grill
8. Convection with bottom heat
9. Convection with top and bottom heat

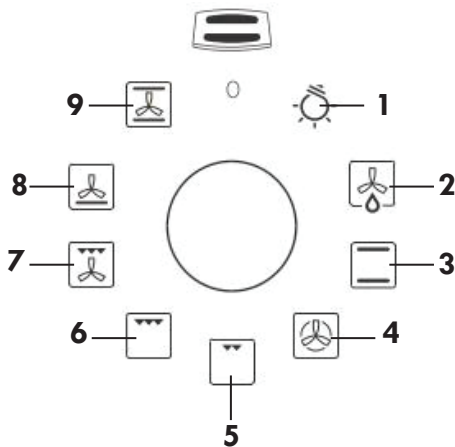

1. OVEN LIGHT

The oven light allows you to clearly view the cooking process through the oven door without opening it. This ensures consistent temperatures are maintained while giving you full control over your dishes.

2. DEFROST

The defrost function circulates room-temperature air evenly throughout the oven, gently and hygienically thawing frozen food. Perfect for bread, cakes, meat, and other frozen items.

3. TOP AND BOTTOM HEAT

The top and bottom heat function provides even heat distribution from both the top and bottom elements, ensuring a consistent cooking temperature. Ideal for baking, roasting, and browning dishes to perfection.

4.CIRCLE FAN HEATER

This function uses a circular heating element surrounding the fan at the back of the oven. The fan distributes the heat evenly throughout the cavity, ensuring consistent cooking results on all levels. Ideal for baking and roasting multiple dishes at the same time without flavor transfer. This function operates with 2100W oven power, delivering optimal performance.

5.GRILL

The Grill function uses intense heat from the top element (1900W) to brown, crisp, and cook dishes quickly. Ideal for grilling meats, toasting bread, or finishing off dishes with a crispy top. The high heat ensures even grilling results, giving your meals a perfect finish.

6.MAXI GRILL

The Maxi Grill function delivers powerful top heat with maximum power, providing intense grilling performance across the entire oven cavity. Perfect for large cuts of meat, grilling vegetables, or toasting bread, it ensures even browning and a crispy finish. The expanded grilling area allows for cooking larger quantities at once, delivering exceptional results every time.

7.CONVECTION GRILL

The Convection Grill function combines the powerful heat of the grill with the even heat distribution of the fan. This ensures your dishes cook quickly while maintaining a crispy, golden exterior. Perfect for grilling meats, fish, and vegetables, it allows for faster cooking with consistent results across multiple levels of the oven.

8.CONVECTION WITH BOTTOM HEAT

The Convection with Bottom Heat function combines the even heat distribution of the fan with gentle heat from the bottom element. This ensures thorough cooking while providing a crispy bottom layer. Ideal for baking pizzas, pies, and other dishes that require a well-cooked base and evenly browned top.

9.CONVECTION WITH TOP AND BOTTOM HEAT FUNCTION

The Convection with Top and Bottom Heat function combines the fan's even heat distribution with both the top and bottom heating elements. This ensures uniform cooking and browning, making it perfect for roasting, baking, and cooking multiple dishes at once. It provides consistent results across all levels of the oven, ideal for achieving perfectly cooked meals with a golden finish.

POP-UP-KNOBS



The KB ELEMENTS electric oven features sleek Pop-Out Control Knobs that can be pressed in for a seamless look and popped out for easy, precise operation.

Elegant design

Smooth, clutter-free front with no protruding knobs – modern and stylish.

Easy to clean

No dirt or grease can collect around sticking-out controls – simply wipe clean.

Safe & practical

No accidental adjustments – the knob is only active when popped out.

AQUA CLEAN

The Aqua Clean function uses the power of steam to make oven cleaning easier. The bottom of the oven is designed to allow water to be poured in. By activating the Convection with Bottom Heat function, the water is heated and evaporates, helping to dissolve grease deposits and dirt inside the oven.

ELECTRONIC TIMER SETTING (3 KEYS)

Operating instructions for Electronic Timer (3 keys)

Before using for the first time

Setting and changing the current time

- **The oven only operates when the time has been set.**

When the appliance has been connected to the electrical supply or when there has been a power cut, the function indicator Time (⌚) flashes automatically.

1. To change the time that has already been set, press the Selection (⌚) button repeatedly, until the function indicator Time (⌚) flashes.
2. Set the current time using the (+) or (-) button.

After approx. 5 seconds, the flashing stops and the clock displays the time of day set.

The oven is now ready to use.

- **The time can only be changed if neither of the automatic functions (Cook time (👨‍🍳)) have been set.**

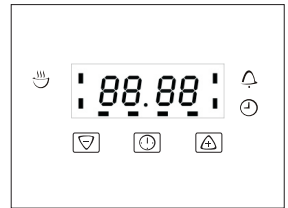
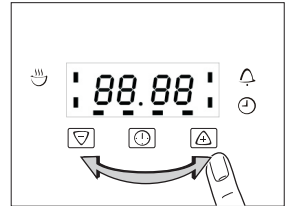
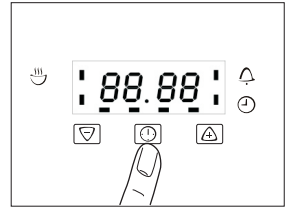

CLOCK FUNCTIONS

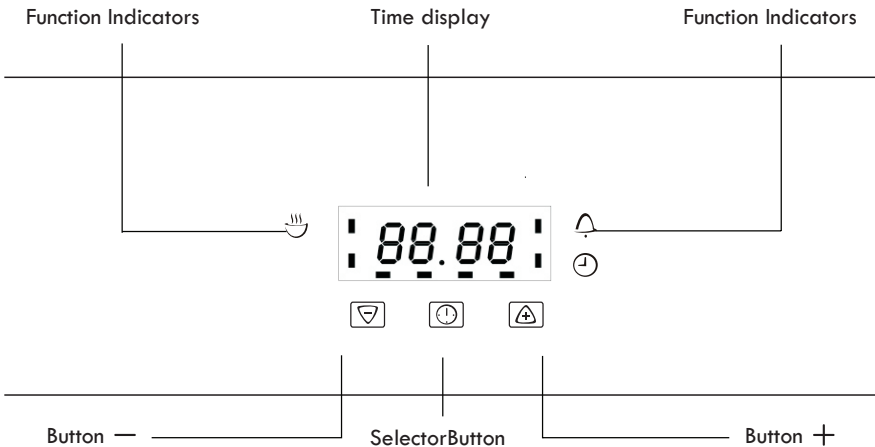

COUNTDOWN

To set a countdown, a signal sounds after the time has elapsed.
This function does not affect the operation of the oven.



COOK TIME

To set how long the oven is to be in use.



TIME

To set, change or check the time (See also section "Before Using for the First Time").



HOW TO USE THE CLOCK FUNCTIONS



- When a function has been selected, the corresponding function indicator flashes for approx. 5 seconds. During this time the desired times can be set using the  or  button.
- When the desired time has been set, the function indicator flashes for approx. another 5 seconds. After that the function indicator is then lit. The set time begins to run.
- Press any of the buttons to stop the acoustic signal.
- The desired oven function and temperature can be selected before or after the clock functions of Cook time 
- When the cooking time has ended, turn the oven function and temperature dial back to the OFF position.

SWITCHING OFF THE TIME DISPLAY

- By switching off the time display you can save energy.
- Switching off the time display
- Hold down any two buttons until the display becomes dark.
- Switching on the time display
- Hold down any button until the time reappears in the display.
- The display can only be switched off if none of the clock functions Cook time  or Countdown  are in use.

COUNTDOWN

Press Selection  button repeatedly, until the function indicator Countdown  flashes.

Using the  or  button, set the required Countdown.

After approx. 5 seconds, the display shows the remaining time.



The function indicator Countdown  will light up.

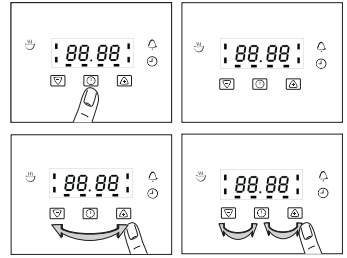

When the time has elapsed, the function indicator flashes and an acoustic signal sounds for 2 minutes.

Press any button to switch off the signal.



COOK TIME

Press Selection  button repeatedly, until the function indicator Cook time  flashes.

Using the  or  button, set the required Cooking time.

After approx. 5 seconds, the display returns to the current time. The function indicator Cook time  will light up.

When the time has elapsed, the function indicator will flash, an acoustic signal will sound for 2 minutes and the oven will switch itself off.

Press any button to switch off the signal and the program.

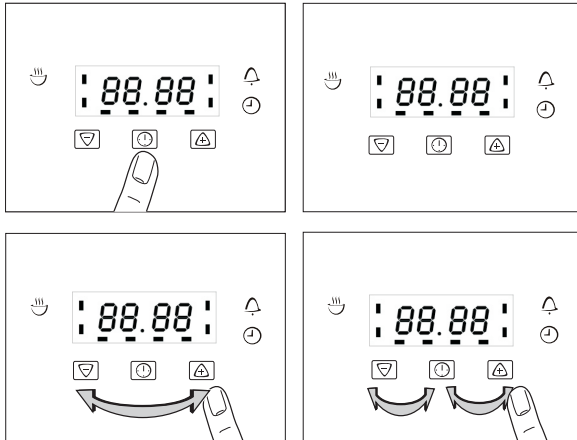

CLEANING THE OVEN DOOR

To make it easier to clean the inside of your oven, the oven door can be removed, by proceeding as follows (fig. 1-2):

- Open the door completely and lift the 2 levers “B” (fig.4);
- Now, shutting the door slightly, you can lift it out by pulling out the hooks “A” as shown in figure 2.

To reassemble the door:

- With the door in a vertical position, insert the two hooks “A” into the slots;
- Ensure that seat “D” is hooked perfectly onto the edge of the slot (move the oven door backwards and forward slightly);
- Keep the oven door open fully, unhook the 2 levers “B” downwards and then shut the door again.

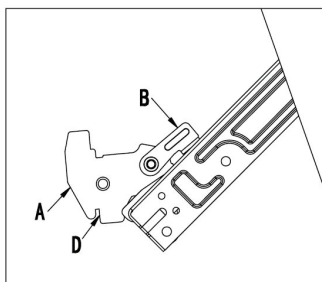

Fig. 4

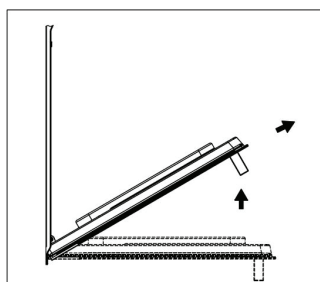

Fig. 5

INSTRUCTION OF REMOVABLE GLAZING DOOR

The oven door is made up of 3 panes of glass and has vents at the top and bottom. When the oven is operating, air is circulated through the door to keep the outer pane cool. If condensation has worked its way in between the glass panes, the door can be dismantled in order to clean in between the panes. Remove the door as per above instruction and place it on a protective surface (e.g. on a table cloth) to prevent it getting scratched. The door handle should line up with the edge of the table. Make sure the glass lies flat to avoid breakage of glass during cleaning.

1. Press the button on left and right side of door, take out top rail. (Fig.6)
2. Take out inner glass slowly (Fig.7)
3. Loose clips. (Fig.8)
4. Take out middle glass. (Fig.9)

Clean the glass panes and other parts with a damp microfibre cloth.

or a clean sponge and a solution of hot water with a little washing-up liquid. Wipe dry using a soft cloth.

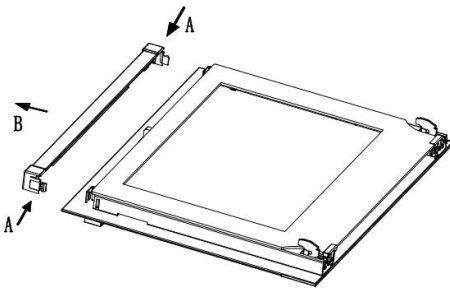

Fig. 6

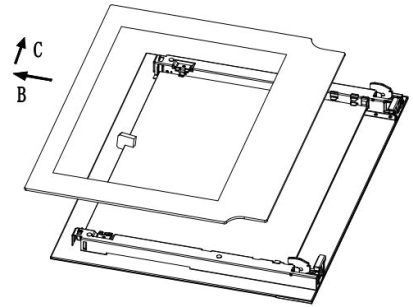

Fig.7

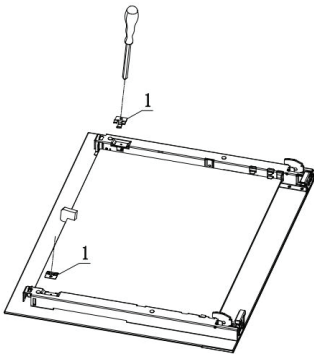

Fig. 8

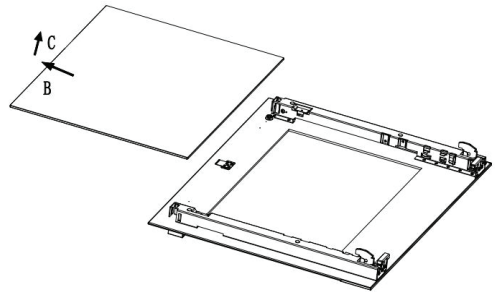

Fig.9

ENVIRONMENTAL INFORMATION ON DISPOSAL

This product must not be disposed of with household waste. Please dispose of it at a collection point for electrical and electronic equipment. This will help conserve resources and prevent environmental pollution. This product bears the crossed-out wheeled bin symbol.



To know more about this product, please visit our youtube channel





www.kbelements.de