

K B ELEMENTS

BUILT-IN ELECTRIC OVEN WITH FULL TOUCH SCREEN

ELK75DV1 - ELK75DV2 - ELK75DV3

USER MANUAL

Please read this manual carefully and retain for future references.

IMPORTANT SAFETY INSTRUCTIONS

- Ensure the oven is properly installed in accordance with national and local safety regulations and all electrical components are correctly set up before use.
 - Remove all packing parts, packing materials and all the protective film (except rating label) before use.
 - To prevent electric shock or fire hazards, do not damage, modify, expose to high temperatures, twist, hang, or pull the power cord too hard.
 - If the power cord is damaged, please contact nearest KB ELEMENTS point of sales for replacement.
 - Before first use, operate the oven empty to eliminate any manufacturing odors.
 - For safety, do not use sealed containers as they may burst under pressure.
 - Ensure the oven door remains closed during operation and is free from obstruction.
 - To prevent electric shock or injury, do not insert any objects, especially metal ones like wires, into the openings.
 - Wear heat-resistant gloves when handling during operation.
 - Do not install decorative door panels, as they may distort from overheating.
 - Maintain a safe distance from the oven during and after use, especially with children around, to avoid burns. Use only heat-resistant pottery inside to reduce fire hazards.
 - To prevent fire, burns, or injury from potential explosions due to pressure buildup, do not place flammable objects like plastic, aluminum foil, or unopened canned products inside the oven.
 - To avoid fire, always monitor the oven when cooking foods with fat or oil.
 - Avoid using the oven to heat the room, as this may cause a fire and reduce its lifespan.
 - Do not disassemble, repair, or modify it yourself. Please contact the nearest KB ELEMENTS point of sale.
 - Do not clean the oven door glass with a rough scrubber or sharp scraper, as it can scratch the glass and potentially cause it to break.
 - Do not clean with a steam cleaner.
 - This oven should be operated only by individuals who are physically, mentally, and sensory capable, unless under supervision or instruction. Ensure children are supervised to ensure their safety and prevent misuse.
 - In case of abnormal operation or malfunction, stop using the oven immediately and unplug it from the power source.
 - Please disconnect the power before replacing the oven's light to prevent the risk of electric shock.
 - Do not touch the bottom when the power is on.
 - Do not touch the sides of the oven door while closing it.
 - Do not leave sugary food residues (such as jam) in the oven.
 - Do not cover the bottom of the oven with aluminum foil, tin foil, or place pans and baking trays directly on the bottom.
 - During oven use, refrain from adding water directly to the baking pan if the surface is still very hot, as this may cause steam, burns, or damage to the enamel surface.
 - It's important to use cleaners that are specifically labeled for use in electric ovens to ensure safety and optimal cleaning results.
- (Avoid actions that could lead to insulation aging and oven damage.)

TECHNICAL SPECIFICATIONS

Model	ELK75DV1 - ELK75DV2 - ELK75DV3
Input	AC 220-240V
Power	3000W
Rated frequency	50/60HZ
Product size(width * depth * height)	59.5cm x 56cm x 59.6cm
Capacity	73L

OVEN STRUCTURE

The Open space oven has a capacity of 73 litres and offers users the option of cooking on 5 shelves at the same time or cooking large quantities which would not necessarily be possible in a traditional oven.

! The first time you use your appliance , heat the empty oven with its door closed at its maximum temperature for at least half an hour . Make sure that the room is well ventilated before switching the oven off and opening the oven door .The appliance may emit a slightly unpleasant odour caused by protective substances used during the manufacturing process burning away.

Never put objects directly on the bottom of the oven ; this will prevent the enamel coating from being damaged.

Always place cookware on the rack (s) provided.

We suggest not opening the door when cooking foodstuffs which require leavening, so as to not compromise cooking results.

FASTENING THE OVEN

Insert the Oven into the compartment; open the oven door and fasten the oven to the cabinet using the two screws "A".

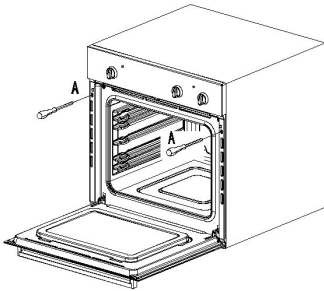

INSTALLATION

Important: the power supply to the oven must be cut off before any adjustments or maintenance work is done on it.

Installation of Built-in Ovens

To ensure the proper working order of the built-in appliance, the kitchen unit must be of a suitable size. The sizes of the unit for installing the cooker under a worktop or in a column unit are shown in figure.

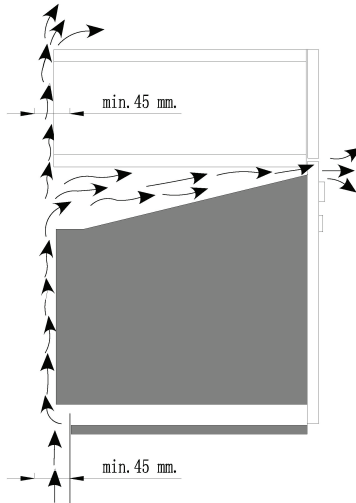

To provide adequate ventilation, there must be appropriate ventilation openings in the front bottom and the top part of 200 cm² , and an exhaust opening on the bottom of an least 200 cm² , and an exhaust opening of at least 60 cm² .

The unit panels next to the cooker must be heat resistant. In the case of veneered wood units, glues must be resistant to a temperature of 120°C.

In accordance with safety standards, once the appliance has been mounted, there must be no possible contact with electrical parts. Any protective parts must be secured so that they can only be removed with the use of tools.

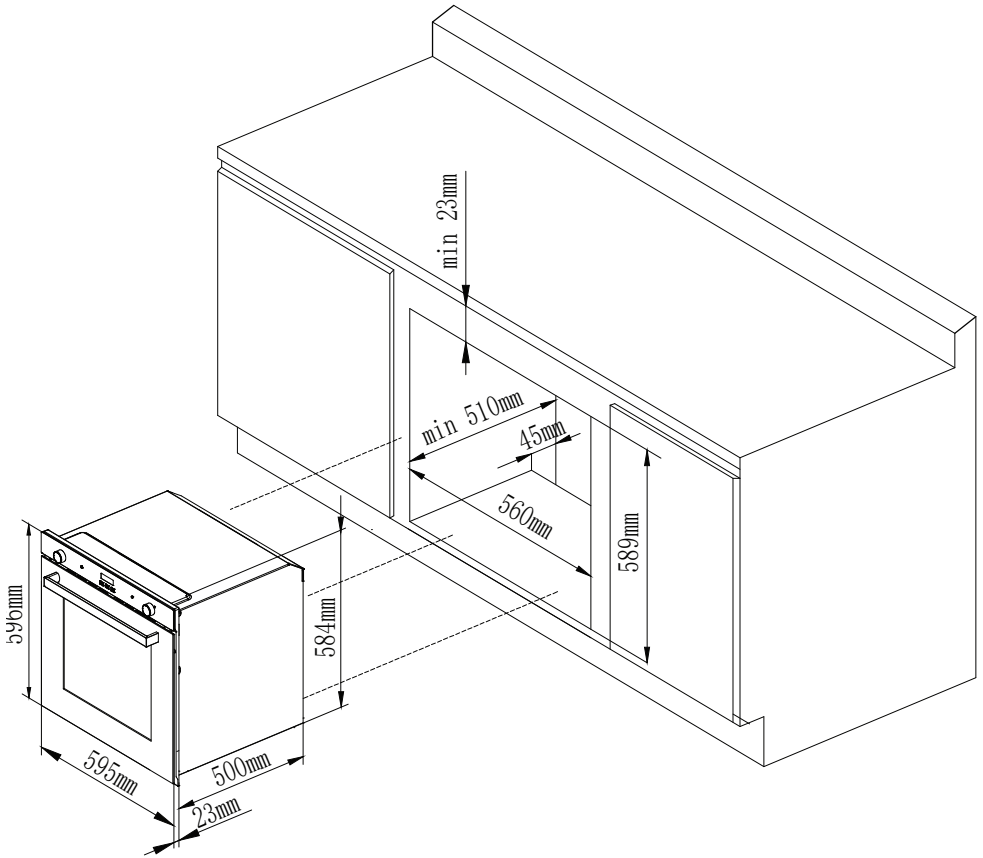

REPLACING THE LAMP IN THE OVEN

- Cut off the supply of power to the oven by turning off the omni-polar switch connecting it to the mains, or by removing the plug if it is accessible; Avoids appearing the electric shock;
- Unscrew the glass cover attached to the lamp holder;
- Pull out the lamp and replace it with another high-temperature lamp (300°C) with the following characteristics:

- Voltage: AC 230V
- Wattage: 25W
- Socket: G9

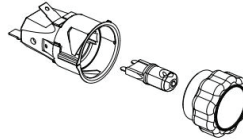

- Remount the glass cover and reconnect the appliance to the power supply.

WARNING: Ensure that the oven is switched off before replacing the lamp to avoid the possibility of electric shock.

FUNCTIONS

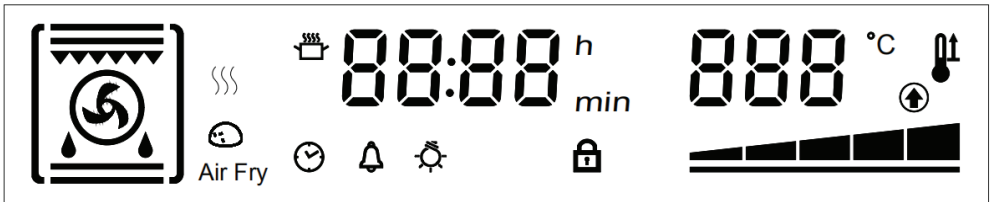

Select Function

1. After the appliance is connected to power, keep pressing **ⓘ** to start oven, press **P** to select function, then press **OK** to confirm.
2. When you switch function, the set End working time and Duration time will be invalid.
3. If working temperature was reset, oven will stop working, and also alarm. Must press OK to restart alarm.
4. New temperature and function setting must be confirmed by pressing OK.
5. Under function mode, keep pressing **ⓘ** to enter standby mode. And display will show current time.

OVEN FUNCTIONS:

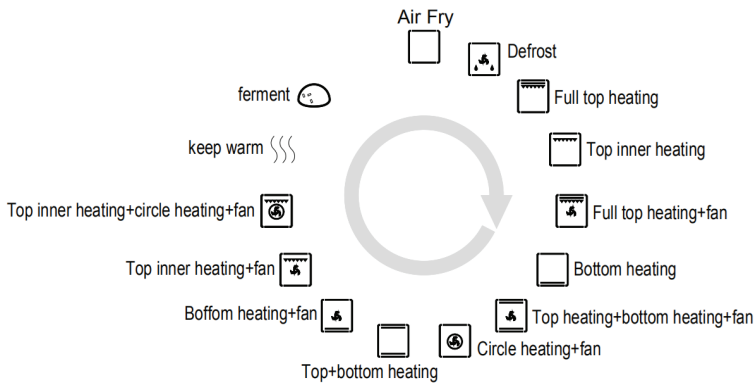

1 Air Fry

Enjoy crispy and golden results with the Air Fry function, which allows oil-free preparation of fries, snacks, and other fried dishes. Perfect for healthy and delicious meals with less oil and more flavor.

2. Defrost

The defrost function provides a gentle, even temperature that allows frozen foods to thaw quickly and evenly. This helps retain nutrients and flavor while ensuring gentle thawing.

3. Maxi Grill

The Maxi Grill function delivers powerful top heat at maximum power, ensuring intense grilling results throughout the oven cavity. Perfect for large cuts of meat, grilled vegetables, or toasting bread.

The extended grill area allows for cooking larger quantities at once, delivering excellent results every time.

4. Grill

The Grill function uses the intense heat from the upper heating element (1900 W) to quickly brown, crisp, and cook dishes. Ideal for grilling meat, toasting bread, or finishing dishes with a crispy top.

The high heat ensures even grilling results and gives your meals the perfect finish.

5. Maxi Grill with Fan

Powerful top heat combined with convection ensures intense and even grilling throughout the oven.

The heat distribution allows for uniform browning and a crispy surface.

6. Bottom Heat

Bottom heat provides direct heat from below and is ideal when targeted bottom heating is required.

It ensures even results for applications where strong bottom heat is important.

7. Top/Bottom Heat with Fan

This function combines top and bottom heat with a convection fan that evenly distributes the hot air in the oven. It ensures consistent temperatures, even cooking on multiple levels, and reliable results for various applications.

8. Hot Air Circulation (Circle Fan Heater)

This function uses a circular heating element around the rear fan of the oven. The hot air is evenly distributed throughout the interior, ensuring consistent temperatures at all levels.

9. Top/Bottom Heat

This classic heating mode uses simultaneous heat from the top and bottom. It provides stable heat distribution without convection and is especially suitable for applications with defined temperature zones.

10. Fan with Bottom Heat

This function combines direct heat from below with evenly circulating hot air. Heat is optimally distributed in the oven, while the bottom heat ensures stable base temperature.

11. Fan with Strong Top Heat (Grill)

This function combines strong top heat with circulating convection. The hot air is evenly distributed, resulting in intense browning and a crispy surface.

12. Fan with Top Heat (Grill) and Circle Heater Fan

This function combines the strong top heat of the grill with even heat distribution through the Circle Heater Fan. The fan ensures optimal circulation of hot air, allowing for intense grilling and browning results.

13. Keep Warm

This function maintains a constant oven temperature of 65°C (149°F) and keeps dishes warm without further cooking. Ideal for keeping meals at the perfect serving temperature.

14. Fermentation

The fermentation function provides an ideal temperature of 34°C (93°F) for dough rising. It maintains consistent warmth to evenly support the fermentation process so the dough rises perfectly.

15. Rapid Heat-Up Function

The Rapid Heat-Up function enables especially fast preheating of the oven. By simultaneously activating multiple heating elements, the desired temperature is reached in the shortest time. Ideal for starting the cooking process quickly and reducing waiting times.

16. Aqua Clean

The Aqua Clean function uses steam to simplify oven cleaning. Water is poured into the specially designed bottom section of the oven. When the fan with bottom heat function is activated, the water heats up and evaporates, loosening grease and dirt inside the oven.

17. Timer

The timer function allows you to set an exact cooking duration. Once the set time has elapsed, an audible signal sounds, and the oven switches off automatically. Ideal for precisely cooking or baking dishes without having to constantly watch the clock.

Oven setting



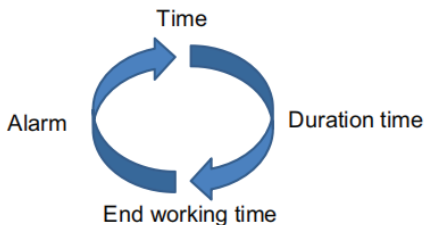

1. Time display area, can show timer, alarm, duration time and end work time. Time and temperature can be set by pressing **+/-** and confirmed by pressing OK.



Time setting sequence





2. Set the alarm. Alarm can be set only when main switch **I** under off status. Press **🕒** for once to enter alarm setting, alarm icon **🔔** keep flashing, and default time is 0:00, press **+/-** to set alarm, and press OK to confirm.

PS: you can cancel alarm by setting time to 0:00.

3. Set the time. Time can be set only when main switch  under off status. Press  twice to enter time setting. Display will show current time. Time icon  will keep flashing, press  to set time. Keep pressing  to speed up setting process. Set time is automatically accepted after 8 seconds, you can also press OK to confirm.



4. Set the duration time. Only function is selected then can set duration time. Press  to enter duration time setting  keep flashing. Press  to set duration time, and press OK to confirm.

5. Set end working time. Only after duration time is set, then press  to enter time setting.  keep flashing Press  to set duration time, and press OK to confirm

6. Children safety lock  Pressing OK for 5s to start or cancel safety lock function.

7. Temperature display  each block show 20% of set temperature.

8. Set temperature. When function is selected, temperature area keep flashing Press  to set temperature, and press OK to confirm.

9. Rapid heat-up  When the setting temperature exceeds 100C and the pre-heat function hasn't been finished, user can press  start the rapid heat-up mode. Display will show  icon continuously.

10. Light. 

CLEANING THE OVEN DOOR

To make it easier to clean the inside of your oven, the oven door can be removed, by proceeding as follows (fig. 1-2):

- Open the door completely and lift the 2 levers "B" (fig.4);
- Now, shutting the door slightly, you can lift it out by pulling out the hooks "A" as shown in figure 2.

To reassemble the door:

- With the door in a vertical position, insert the two hooks "A" into the slots;
- Ensure that seat "D" is hooked perfectly onto the edge of the slot (move the oven door backwards and forward slightly);
- Keep the oven door open fully, unhook the 2 levers "B" downwards and then shut the door again.

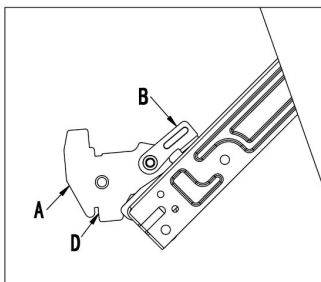

Fig. 4

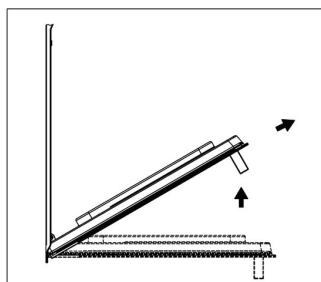

Fig. 5

INSTRUCTION OF REMOVABLE GLAZING DOOR

The oven door is made up of 3 panes of glass and has vents at the top and bottom. When the oven is operating, air is circulated through the door to keep the outer pane cool. If condensation has worked its way in between the glass panes, the door can be dismantled in order to clean in between the panes. Remove the door as per above instruction and place it on a protective surface (e.g. on a table cloth) to prevent it getting scratched. The door handle should line up with the edge of the table. Make sure the glass lies flat to avoid breakage of glass during cleaning.

1. Press the button on left and right side of door, take out top rail. (Fig.6)
2. Take out inner glass slowly (Fig.7)
3. Loose clips. (Fig.8)
4. Take out middle glass. (Fig.9)

Clean the glass panes and other parts with a damp microfibre cloth.

or a clean sponge and a solution of hot water with a little washing-up liquid. Wipe dry using a soft cloth.

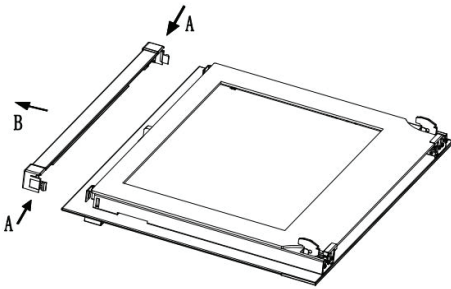

Fig. 6

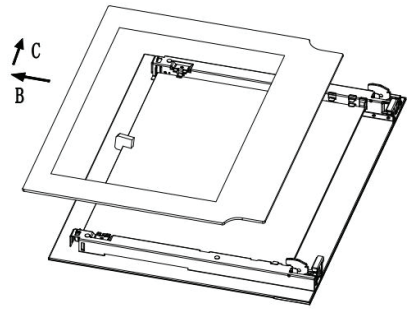

Fig.7

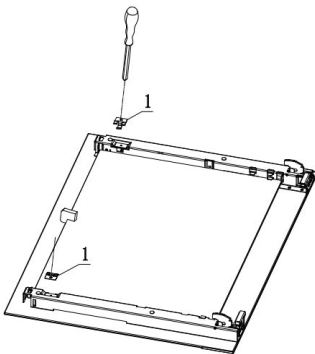

Fig 8

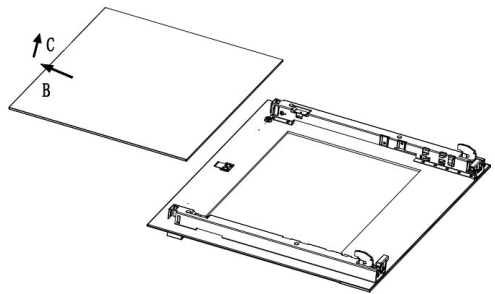

Fig 9

ENVIRONMENTAL INFORMATION ON DISPOSAL

This product must not be disposed of with household waste. Please dispose of it at a collection point for electrical and electronic equipment. This will help conserve resources and prevent environmental pollution. This product bears the crossed-out wheeled bin symbol.



To know more about this product, please visit our youtube channel





www.kbelements.de