

# **K B** ELEMENTS

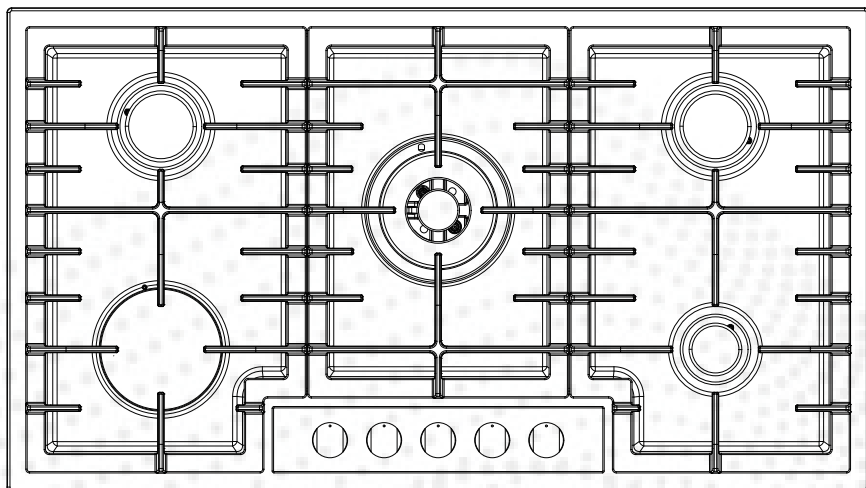

**5 BURNERS BUILT-IN GAS COOKTOP**

**ELK90GH1**

**USER MANUAL**

Please read this manual carefully and retain for future references.

## WARNING BEFORE FIRST USE

This appliance may be used by children aged 8 years and over and by persons with reduced physical, sensory, or mental capabilities or lack of experience and knowledge, provided they are supervised or have been instructed on the safe use of the appliance and understand the hazards involved. Children must not play with the appliance. Cleaning and user maintenance must not be carried out by children without supervision.

**CAUTION:** The use of a gas cooking appliance results in the production of heat, moisture, and products of combustion in the room in which it is installed. Ensure that the kitchen is adequately ventilated, especially when the appliance is in operation.

Prolonged, intensive use of the appliance may require additional ventilation, for example by increasing existing mechanical ventilation or by providing additional ventilation measures to safely remove combustion products to the outside (fresh air), while ensuring adequate air exchange in the room. Consult a qualified professional before installing additional ventilation equipment.

**CAUTION:** This appliance is intended for cooking purposes only and must not be used for any other purpose, for example for heating rooms.

If the grill can be used with the door open, the following notice must be particularly emphasized (e.g. by color or underlining):

**CAUTION:** Accessible parts may become hot when the grill and/or oven is in operation.

Keep small children away.

**CAUTION:** If the glass surface breaks: immediately switch off all burners and all electrical heating elements and disconnect the appliance from the power supply. Do not touch the appliance surface and do not continue to use the appliance.

Children must not play with the appliance. Cleaning and user maintenance must not be carried out by children without supervision.

## TECHNICAL DATA

Model: ELK90GH1

Number of burners: 5 full copper burners

Hob material: Stainless steel 304

Pan supports: Cast iron

Safety devices: Automatic safety shut-off in case of gas leaks

Wok Burner: 3,4 KW

Rapid burner power: 2.4 kW

Standard burner power: 1.88 kW

Simmer burner power: 0.9 kW

Gas type: Natural gas / LPG

Ignition: Piezo

Dimensions (W × D × H): 909 × 510 × 85 mm

Built-in dimensions (W × D): 872 × 470 mm

Weight: 17 kg

Plug: Schuko plug

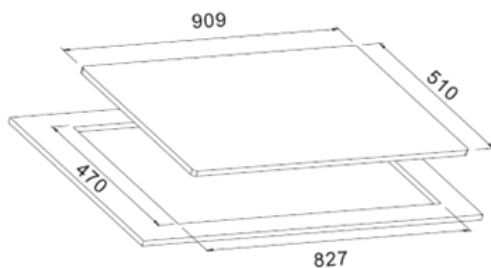

## ACCESSORIES:

Installation kit

LPG gas connection adapter

Gas connection elbow

LPG gas nozzles 30 mbar (for use with a 30 mbar pressure regulator)

LPG gas nozzles 50 mbar (for use with a 50 mbar pressure regulator)

## PRODUCT OVERVIEW

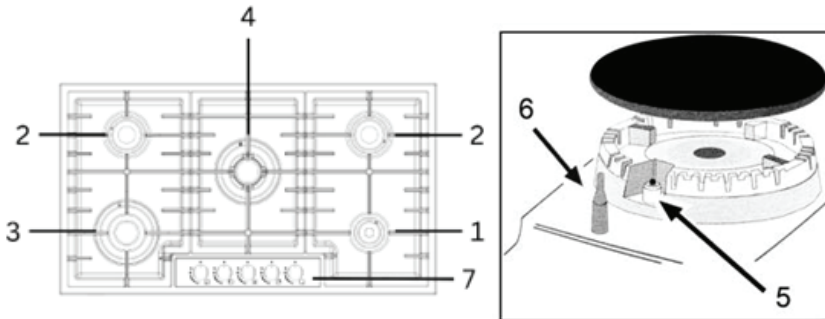

1. Simmer burner
2. Standard burner
3. Rapid burner
4. Wok burner
5. Gas burner ignition device
6. Safety device
7. Gas burner control knob

# INSTALLATION

## Important notice before use

The hob is factory-set for natural gas (NG). If you intend to use liquefied petroleum gas (LPG) from a gas cylinder, the corresponding LPG nozzles must be installed. To do so, replace the pre-installed nozzles with the supplied LPG nozzles.

The LPG nozzles are available in two versions: 50 mbar and 30 mbar. Please check the pressure of your gas regulator to determine which LPG nozzles are suitable for your installation.

The following instructions are intended for a qualified installer to ensure that installation and maintenance are carried out as professionally and correctly as possible.

### Important:

1. Always disconnect the appliance from the power supply before carrying out any maintenance or adjustment work.
2. Before installation, ensure that the local supply conditions (type of gas and gas pressure) are compatible with the appliance settings. The setting conditions for this appliance are indicated on the rating plate.

This appliance is not connected to a device for the discharge of combustion products. It must be installed and connected in accordance with current installation regulations. Particular attention must be paid to the applicable ventilation requirements.

## Positioning of the Gas Hob

Important: This appliance must only be installed and operated in permanently ventilated rooms.

The following requirements must be observed:

- a) The room must be equipped with a ventilation system that discharges smoke and combustion gases to the outside.

This must be achieved by means of an extractor hood or an electric fan that automatically switches on as soon as the hood is put into operation.



Into a chimney flue or into a branched flue system.



Directly to the outside.

b) The room must also allow for the supply of air for proper combustion. The airflow for combustion must not be less than  $2 \text{ m}^3/\text{h}$  per kW of nominal power. This air supply can be provided directly from outside through a duct with a minimum internal cross-section of  $100 \text{ cm}^2$ , which must not be accidentally blocked. Appliances that are not equipped with a safety device to prevent accidental flame extinction must have a ventilation opening twice as large, i.e., at least  $200 \text{ cm}^2$  (see Fig. 3). Alternatively, the room can be ventilated indirectly through adjacent rooms that have ventilation ducts leading outside, as described above, provided that the adjacent rooms are not common areas, bedrooms, or areas at risk of fire (see Fig.).

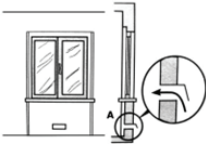

Examples of Ventilation Openings for Combustion Air Supply

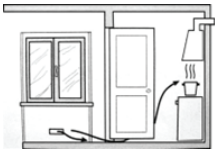

Enlargement of the ventilation slot between the window and the floor.

c) Intensive or prolonged use of the appliance may require additional ventilation, for example by opening a window or increasing the capacity of the air supply system (if present).  
d) Liquefied petroleum gas (LPG) is heavier than air and therefore sinks. Rooms where LPG cylinders are stored must have ventilation openings to the outside to allow gas to escape in case of a leak. Therefore, LPG cylinders, whether empty or partially filled, must not be installed or stored in rooms or areas below ground level (e.g., basements). It is also recommended to keep only the cylinder currently in use in the room and ensure it is not placed near heat sources (ovens, fireplaces, stoves, etc.) that could raise the temperature inside the cylinder above  $50^\circ\text{C}$ .

The gas hobs are equipped with an overheat protection rating of type X. The appliance can therefore be installed next to cabinets, provided that the cabinet height does not exceed that of the hob. For correct installation of the hob, the following precautions must be observed:

- The hob may be installed in a kitchen, kitchen/dining area, or living/sleeping area, but not in a bathroom or shower room.
- Furniture that is higher than the worktop and placed directly next to the hob must be at least  $110 \text{ mm}$  from the edge of the worktop.
- Cabinets adjacent to the extractor hood should be positioned at a minimum height of  $420 \text{ mm}$ .

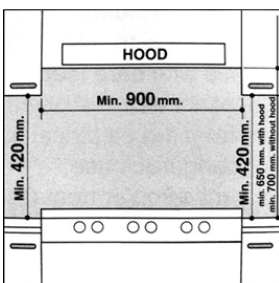

- d) If the hob is installed directly under a cabinet, the distance must be at least 700 mm from the worktop.
- e) The hob can be mounted on worktops with a thickness of 20 to 40 mm using the supplied mounting hooks (see Fig.).

To securely fix the hob, all supplied mounting components should be used.

Note: Use the hook from the "accessory set."

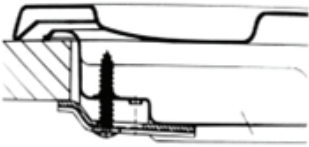
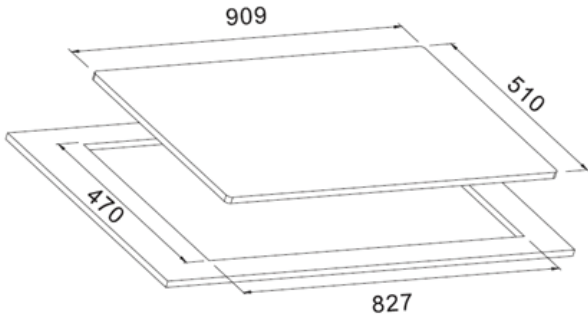

Hook position for 20 mm worktop thickness

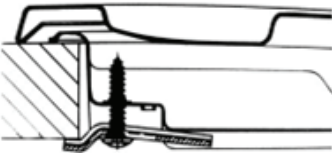

Hook position for 30 mm worktop thickness

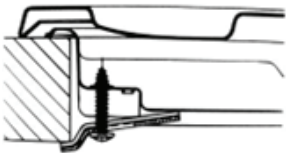

Hook position for >40 mm worktop thickness

## **GAS CONNECTION FOR THE GAS HOB**

The hob should be connected to the gas supply by a certified gas technician.

During the installation of this appliance, it is essential to install an approved shut-off valve to allow the gas supply to the appliance to be safely interrupted for any future disassembly or maintenance. The connection of the appliance to the gas network or LPG must be carried out in accordance with applicable regulations and may only be performed if it is ensured that the appliance is suitable for the type of gas being used. If this is not the case, refer to the instructions in the section “Adapting to Different Gas Types.”

In the case of connection to LPG via a gas cylinder, pressure regulators that comply with applicable regulations must be used.

### **Connection to a rigid pipe (copper or steel):**

The connection to the gas supply must be made so that no stress or strain occurs at any point of the appliance.

The appliance is equipped with an adjustable, “L”-shaped connector and a gasket for connection to the gas supply.

If this connector needs to be rotated, the gasket must be replaced (supplied with the appliance). The appliance’s gas inlet connection is a 1/2" male gas thread.

### **Connection to a flexible steel hose:**

The appliance gas connection is a 1/2" male thread for a round pipe.

Only pipes and gaskets that comply with current standards may be used.

The maximum length of the flexible hose must not exceed 2000 mm.

After connection, ensure that the flexible metal hose does not touch any moving parts and is not pinched.

### **Checking the gasket:**

After the appliance is installed, ensure all connections are leak-tight by using a soap-and-water solution.

Never use an open flame to check for leaks.

## **REPLACING THE BURNER NOZZLE**

Loosen the nozzle using a wrench.

Install the new nozzle suitable for the required type of gas.

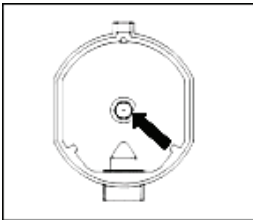

### **Valve Adjustment**

The valve adjustment should be carried out when the knob is in the “Burner ON – Low Flame” position. Remove the knob and adjust the flame using a small screwdriver (see figure below).

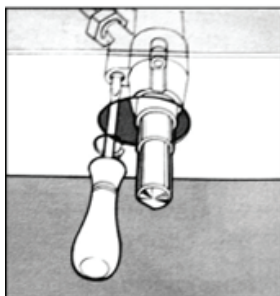
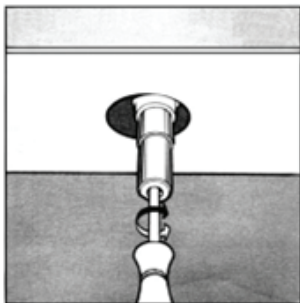

### Checking the Adjusted Flame

Burn the burner for 10 minutes in the full flame position.

Then turn the knob to the low flame position.

The flame must not go out or move toward the nozzle.

If this occurs, readjust the valve.

#### Note:

It is the user's responsibility to have the appliance converted to a different type of gas by a certified gas technician, if required by local conditions.

### Turning on a Burner:

Press the corresponding knob fully down and turn it counterclockwise to the "High" ( 🔥 ) position.

Hold the knob down until the burner ignites.

**Note:** If the burner goes out accidentally, turn the knob to "OFF" (\*) and wait at least 1 minute before attempting to ignite it again.

### Turning off a Burner:

Turn the knob clockwise until it stops (on the "\*" mark).

### Flame Adjustment:

At the beginning of cooking, the burner should be set to a high flame to bring the food to a boil.

Then, turn the knob to the low flame position to continue cooking.

It is also possible to adjust the flame size continuously.

### Notes on Flame Adjustment and Energy Saving:

- It is prohibited to set the flame between the "Burner OFF" position and the "Burner ON – High Flame" position.
- Significant energy savings can be achieved if the appliance is used correctly, parameters are properly set, and suitable cookware is used. Savings can include:
  - Up to 60% saving when using appropriate pots and pans.
  - Up to 60% saving when the appliance is operated correctly and the appropriate flame size is selected.

For efficient and energy-saving operation of the hob, the burners must always be kept clean, particularly the flame slots and nozzles.

## CLEANING

### Keep your hob in top condition

Before cleaning or performing maintenance on your appliance, always disconnect it from the power supply.

To extend the lifespan of your hob, it is essential to clean it regularly and thoroughly, keeping the following in mind:

- Enamelled parts and the glass hob surface, if present, should be cleaned with warm water only. Do not use abrasive powders or aggressive substances that could cause damage.
- Removable burner parts should be cleaned regularly with warm water and soap, making sure to remove any dried-on residues.
- For hobs with automatic ignition, the tip of the electronic ignition device should be cleaned regularly and carefully, ensuring that the gas holes are not blocked.
- Stainless steel may stain if exposed for a long time to hard water or aggressive cleaning agents (containing phosphorus). It is recommended to rinse these parts thoroughly with water and dry them well. It is also advisable to clean up any spills immediately.

## TROUBLESHOOTING

Sometimes the hob may not operate or may not function correctly. Before contacting customer service, please check what can be done on your own.

First, ensure that there are no interruptions in the gas and power supply, and particularly that the main gas valves are open.

The burner will not ignite or the flame is uneven

Check that:

- The gas holes on the burner are not blocked.
- All movable parts of the burner are correctly assembled.
- There are no drafts near the hob.

The flame does not stay lit on models with a safety device

Check that:

- You are pressing the knob fully down.
- You are holding the knob long enough to activate the safety device.
- The gas holes in the area of the safety device are not blocked.

The burner does not stay on at "Low"

Check that:

- The gas holes are not blocked.
- There are no drafts near the hob.
- The minimum setting is correctly adjusted (see section "Minimum Regulation").

Cookware is unstable

Check that:

- The base of the cookware is completely flat.
- The cookware is correctly centered on the burner or electric plate.
- The pan supports have not been swapped.

If the hob still does not work properly despite all checks, please contact the nearest Merloni Elettrodomestici service center and provide the following information:

- Type of problem
- Model identification abbreviation (Mod....) as indicated on the warranty

**Note: Never call technicians who are not authorized by the manufacturer, and do not accept spare parts that are not original.**

## PROPER DISPOSAL OF THIS PRODUCT



This appliance must not be disposed of with regular household waste. It should be taken to a designated collection point for the recycling of electrical and electronic equipment.

By disposing of the appliance correctly, you help prevent potential environmental and health hazards caused by improper waste handling.

For more information about recycling this product, please contact your local municipal office, waste disposal service, or the store where you purchased the appliance.



[www.kbelements.de](http://www.kbelements.de)